

## Circuit Breaker Panel

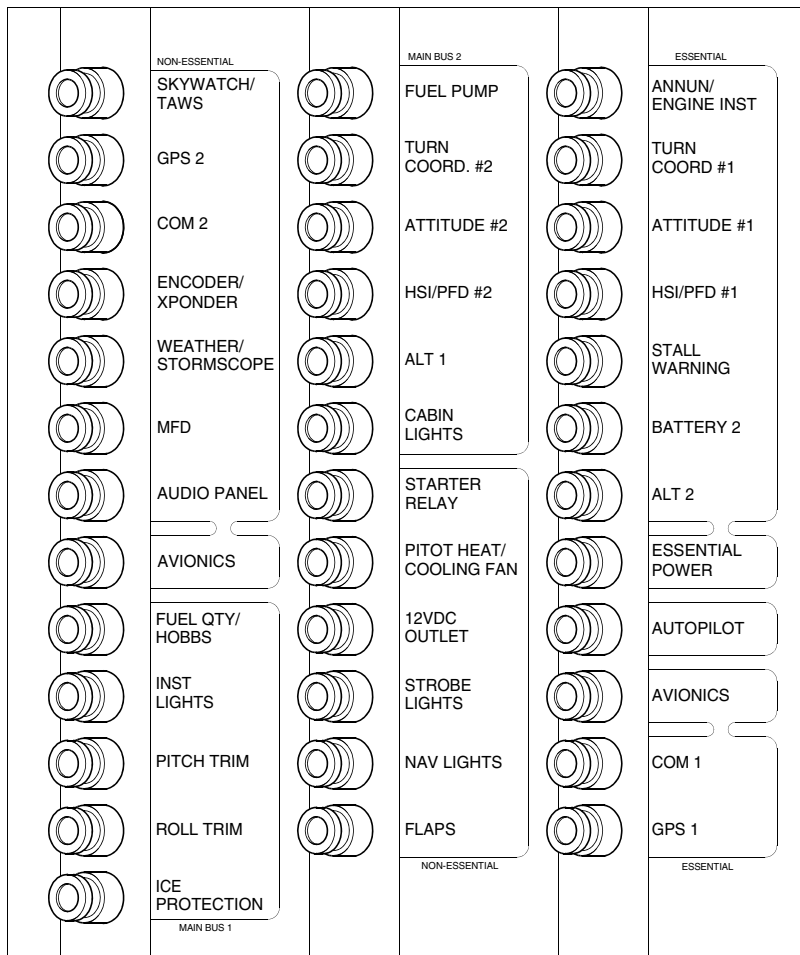

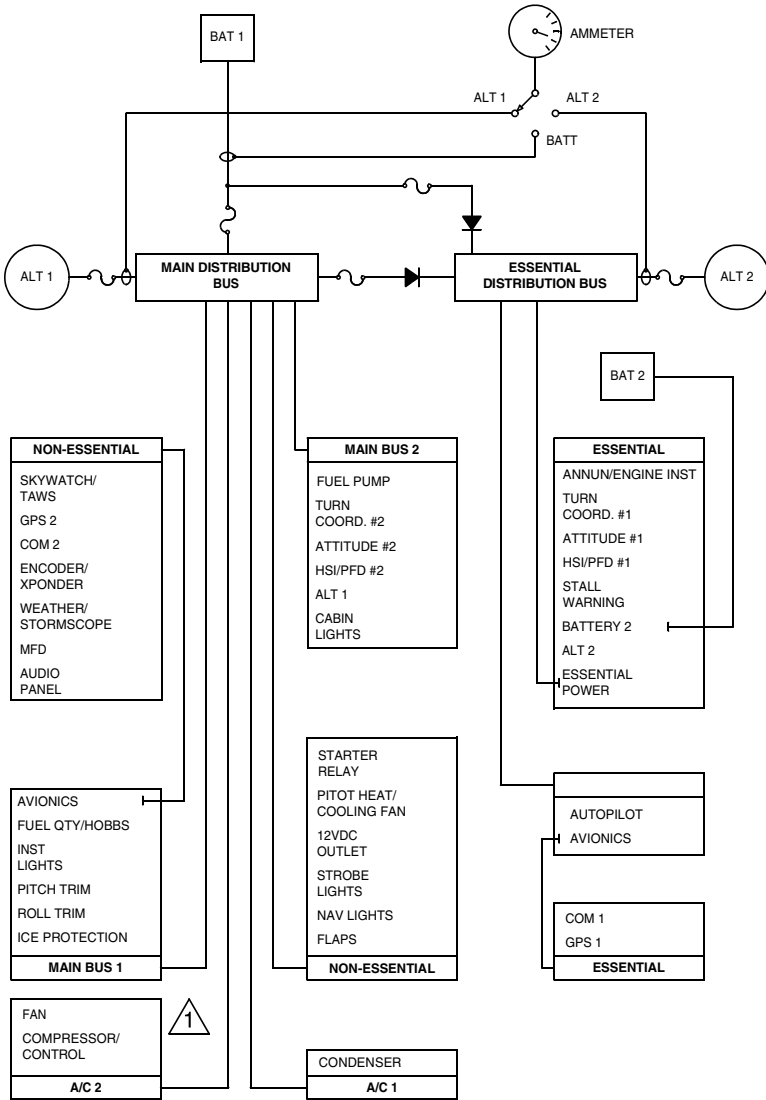

**NOTE**

1 Serials 1633, 1639 & subs with optional Blower Fan installed.

SR20\_FM03\_1453E

**Figure 3A-1**  
**Electrical Power Distribution (Simplified)**

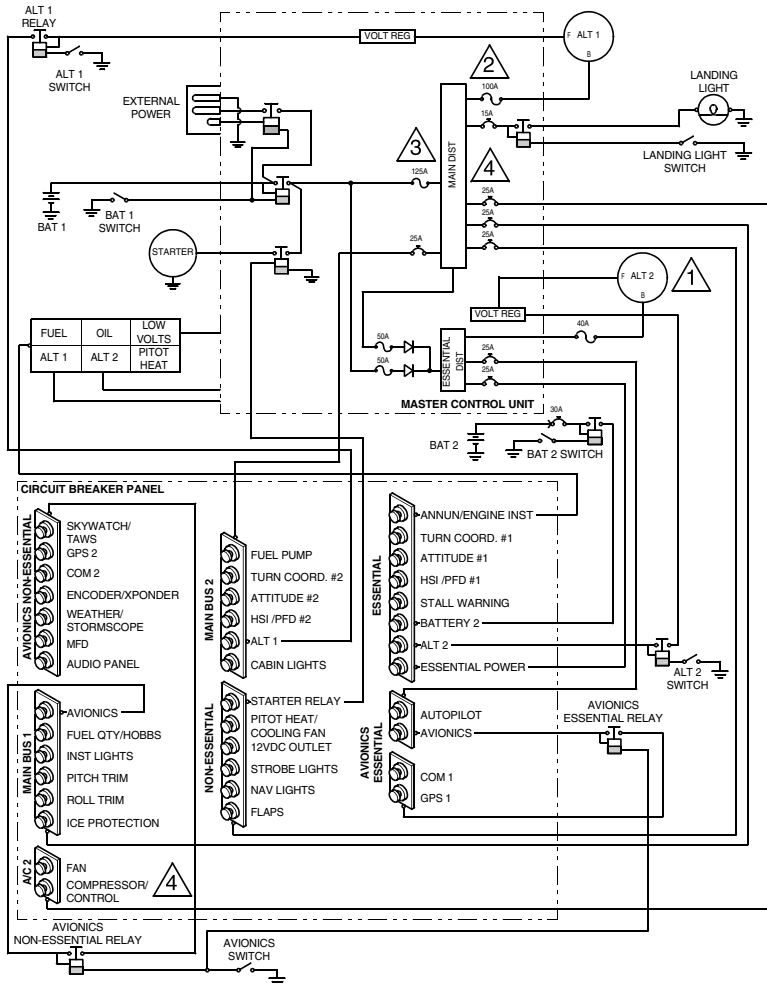

**NOTE**

- ① *Serials 1359 and subsequent with SRV option:* The airplane is equipped with a single alternator, dual battery electrical system. This configuration is identical to the dual alternator system except components used in conjunction with the secondary alternator are removed.
- ② *Serials 1005 thru 1581:* 80A fuse.
- ③ *Serials 1005 thru 1581:* 100A fuse.
- ④ *Serials 1633, 1639 & subs with optional Blower Fan installed.*

SR20\_FM07\_1722D

**Figure 7-13**  
**Electrical System Schematic**